

## uGuard2804 TVS Arrays



### Description

The uGuard2804 TVS diode is a low capacitance TVS (Transient Voltage Suppressor) device specifically designed to meet the EOS (Electrical Over-Stress) protection requirements of Gigabit Ethernet interfaces. The uGuard2804 is designed to protect sensitive PHY (physical layer) chips from damage due to EOS events such as electrostatic discharge (ESD), lightning, electrical fast transients (EFT), and cable discharge events (CDE). The uGuard2804 is constructed with a proprietary process that ensures low leakage (“idle”) current and low junction capacitance when used in low voltage applications. The device has minimal change in junction capacitance, as a function of bias voltage variations, which facilitates stable operation on GbE lines and interfaces. The uGuard2804 is in an 8-pin SO-8 package with lead-free matte tin lead finish. The combination of low clamping voltage, high surge capability, low “idle” current and low capacitance makes the uGuard2804 an ideal solution for protecting sensitive GbE systems in accordance with the transient protection immunity requirements of GR-1089.

### Circuit Diagram

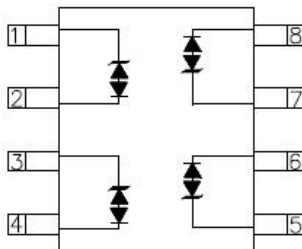

### Features

- High ESD withstand Voltage:  $\pm 15\text{kV}$  (air),  $\pm 8\text{kV}$  (contact) per IEC 61000-4-2
- Multiple surge event capability (1000 events) per IEC 61000-4-2 Level 4
- High peak power capability (120W)
- Flow-through design minimizes parasitic inductance for reduced voltage overshoot
- Protects two line pairs
- Low reverse “idle” current: 30nA typical ( $V_R=2.8\text{V}$ )
- Low variation in capacitance vs. bias voltage: 1.3pF Typical ( $V_R = 0$  to 2.8V)
- Low working voltage: 2.8V
- Solid-state silicon design – no inherent wear out mechanism
- Industry standard package footprint

### Mechanical Characteristics

- JEDEC SO-8 package
- Pb-Free, Halogen Free, RoHS/WEEE Compliant
- Lead Finish: Matte tin
- Molding compound flammability rating: UL 94V-0
- Marking: Marking code, date code
- Packaging: Tape and Reel

### Applications

- 10/100/1000 Ethernet
- Integrated magnetics/RJ-45 connectors
- LAN/WAN Equipment
- User interface
- Integrated Circuit (IC)  $V_{\text{bus}}$
- Peripheral power and accessory ports

### Ordering Information

Device	Package	Shipping
uGuard2804	SO-8(Pb-Free)	3000pcs / reel

For information on tape and reel specifications, including part orientation and tape sizes, please refer to our tape and reel packaging specification.

- China - Germany - Korea - Singapore - United States •
- <http://www.smc-diodes.com> - [sales@smc-diodes.com](mailto:sales@smc-diodes.com) •

**Maximum Ratings @ $T_A=25^{\circ}\text{C}$  unless otherwise specified**

Parameter	Symbol	Value	Units
Peak Pulse Power ( $t_p = 8/20\mu\text{s}$ )	$P_{pk}$	120	W
Peak Pulse Current ( $t_p=8/20\mu\text{s}$ )	$I_{PP}$	10	A
ESD per IEC 61000-4-2 (Air) ESD per IEC 61000-4-2 (Contact)	$V_{ESD}$	+/- 15 +/- 8	KV
Operating Junction Temperature Range	$T_J$	-40 to + 125	$^{\circ}\text{C}$
Storage Temperature Range	$T_{STG}$	-55 to + 150	$^{\circ}\text{C}$

**Electrical Characteristics**

Characteristics	Symbol	Condition	Min.	Typ.	Max.	Units
Reverse Breakdown Voltage	$V_{BR}$	@ $I_R = 50\text{mA}$	3.5	-	4.3	V
Reverse Stand-Off Voltage	$V_{RWM}$	-	-	-	2.8	V
Reverse Leakage Current	$I_R$	@ $V_{RWM} = 2.8\text{V}$	-	0.03	0.05	$\mu\text{A}$
Clamping Voltage	$V_C$	@ $I_{PP} = 1\text{A}$ , $t_p=8/20\mu\text{s}$	-	-	6	V
Clamping Voltage	$V_C$	@ $I_{PP} = 10\text{A}$ , $t_p=8/20\mu\text{s}$	-	-	12	V
Variation in capacitance with reverse bias		@ $V_R = 0$ to $2.8\text{V}$ , $f_{SIG} = 1\text{MHz}$ Pins 1, 8 to 2, 7 and pins 3, 6 to 4, 5	-	1.3	-	pF
Junction Capacitance	$C_j$	@ $V_R = 2.8\text{V}$ , $f_{SIG} = 1\text{MHz}$ Pins 1, 8 to 2, 7 and pins 3, 6 to 4, 5	-	3.2	6	pF

\* Pulse width < 300  $\mu\text{s}$ , duty cycle < 2%

**Ratings and Characteristics Curves**

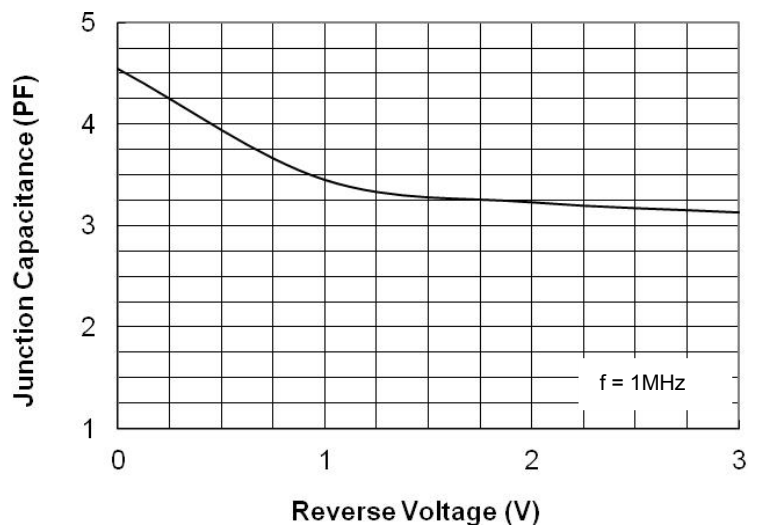
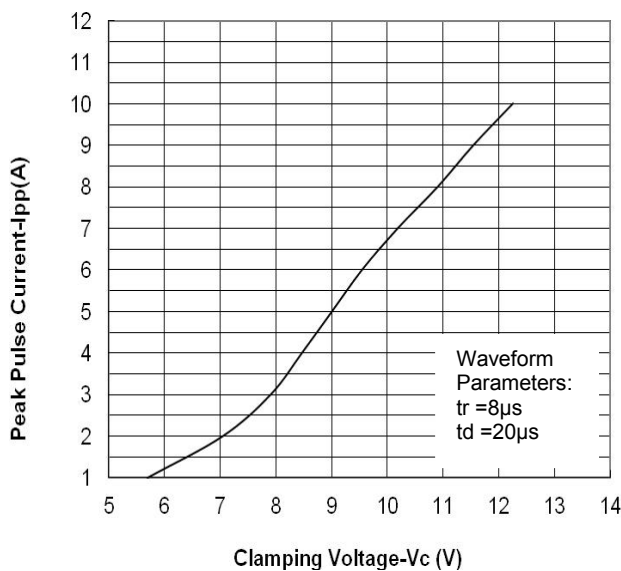

Fig. 1 Typical Clamping Voltage vs. Peak Pulse Current

Fig. 2 Junction Capacitance vs. Reverse Voltage

- China - Germany - Korea - Singapore - United States •
- <http://www.smc-diodes.com> - [sales@smc-diodes.com](mailto:sales@smc-diodes.com) •

**Circuit Diagram**

The uGuard2804 is designed to protect four high-speed data lines (two differential pairs) from transient over-voltages which result from lightning and ESD. Data line inputs/outputs are connected at pins 1 and 8, 2 and 7, 3 and 6, and 4 and 5.

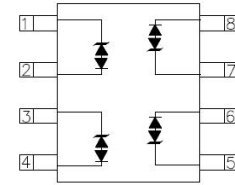

**Part Name Information**

uGuard 28 04

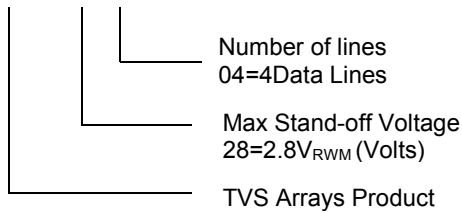

**Marking Diagram**

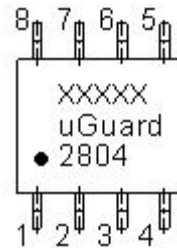

Where XXXXX is YYYYWL

Guard2804 = Part Name  
YY = Year  
WW = Week  
L = Lot Number

**Cautions:** Molding resin  
Epoxy resin UL:94V-0

**Mechanical Dimensions SO-8**

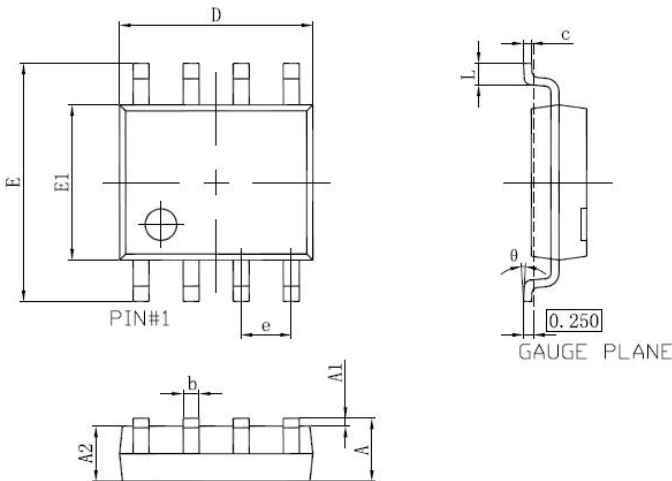

SYMBOL	Millimeters		Inches	
	MIN.	MAX.	MIN.	MAX.
A	1.350	1.750	0.053	0.069
A1	0.100	0.250	0.004	0.010
A2	1.350	1.550	0.053	0.061
b	0.330	0.510	0.013	0.020
c	0.170	0.250	0.007	0.010
D	4.800	5.000	0.189	0.197
e	1.270(BSC)		0.050(BSC)	
E	5.800	6.200	0.228	0.244
E1	3.800	4.000	0.150	0.157
L	0.400	1.270	0.016	0.031
θ	0°	8°	0°	8°

**Carrier Tape & Reel Specification SO-8**

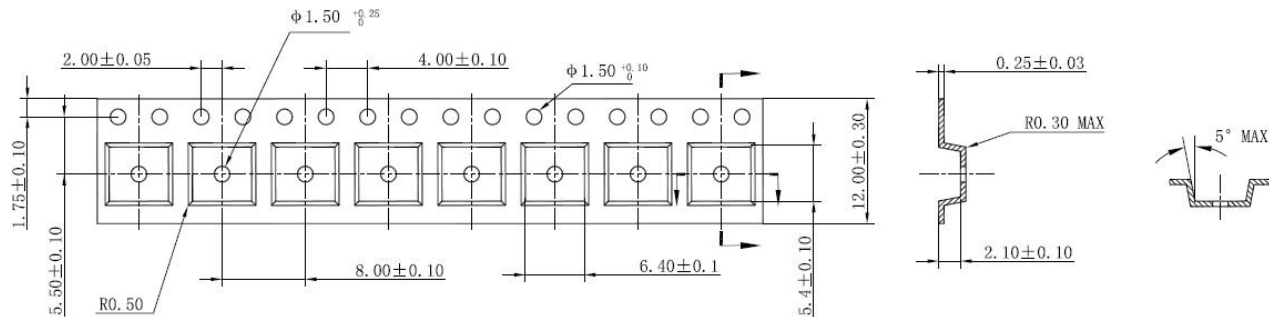

**DISCLAIMER:**

- 1- The information given herein, including the specifications and dimensions, is subject to change without prior notice to improve product characteristics. Before ordering, purchasers are advised to contact the SMC - Sangdest Microelectronics (Nanjing) Co., Ltd sales department for the latest version of the datasheet(s).
- 2- In cases where extremely high reliability is required (such as use in nuclear power control, aerospace and aviation, traffic equipment, medical equipment , and safety equipment) , safety should be ensured by using semiconductor devices that feature assured safety or by means of users' fail-safe precautions or other arrangement .
- 3- In no event shall SMC - Sangdest Microelectronics (Nanjing) Co., Ltd be liable for any damages that may result from an accident or any other cause during operation of the user's units according to the datasheet(s). SMC - Sangdest Microelectronics (Nanjing) Co., Ltd assumes no responsibility for any intellectual property claims or any other problems that may result from applications of information, products or circuits described in the datasheets.
- 4- In no event shall SMC - Sangdest Microelectronics (Nanjing) Co., Ltd be liable for any failure in a semiconductor device or any secondary damage resulting from use at a value exceeding the absolute maximum rating.
- 5- No license is granted by the datasheet(s) under any patents or other rights of any third party or SMC - Sangdest Microelectronics (Nanjing) Co., Ltd.
- 6- The datasheet(s) may not be reproduced or duplicated, in any form, in whole or part, without the expressed written permission of SMC - Sangdest Microelectronics (Nanjing) Co., Ltd.
- 7- The products (technologies) described in the datasheet(s) are not to be provided to any party whose purpose in their application will hinder maintenance of international peace and safety nor are they to be applied to that purpose by their direct purchasers or any third party. When exporting these products (technologies), the necessary procedures are to be taken in accordance with related laws and regulations..