

Technical Data  
Data Sheet N1586 Rev. -

**300mA, Low Dropout Linear Regulator with Shutdown**

**Description:**

The SULR1731 is a 300mA low noise, low dropout linear regulator, and is housed in a small SOT-23-5 package. The device is in the “ON” state when the SHDN pin is set to logic high level. An internal P MOSFET pass transistor is used to achieve 470mV low dropout voltage at 300mA load current. It offers high precision output voltage of  $\pm 2\%$ . The quality of low quiescent current and low dropout voltage makes this device ideal for battery power applications. The internal reverse bias protection eliminates the requirement for a reverse voltage protection diode. The high ripple rejection and low noise of SULR1731 provide enhanced performance for critical applications. The noise bypass pin can be connected an external capacitor to reduce the output noise level.

**Features:**

- Active Low Shutdown Control.
- Very Low Quiescent Current.
- Very Low Dropout Voltage of 470mV at 300mA Output Current (3.0V Output Version)
- 1.3V, 1.5V, 1.8V, 2.5V, 2.8V, 3.0V, 3.3V Output Voltage.
- Short Circuit and Thermal Protection.
- $\pm 2\%$  Output Tolerance.
- Miniature Package: SOT-23-5.

**Applications:**

- PDA
- DSC
- Notebook
- Pagers
- Personal Communication Equipment
- Cordless Telephones
- Portable Instrumentation
- Portable Consumer Equipment
- Battery Powered Systems

**Typical application circuit:**

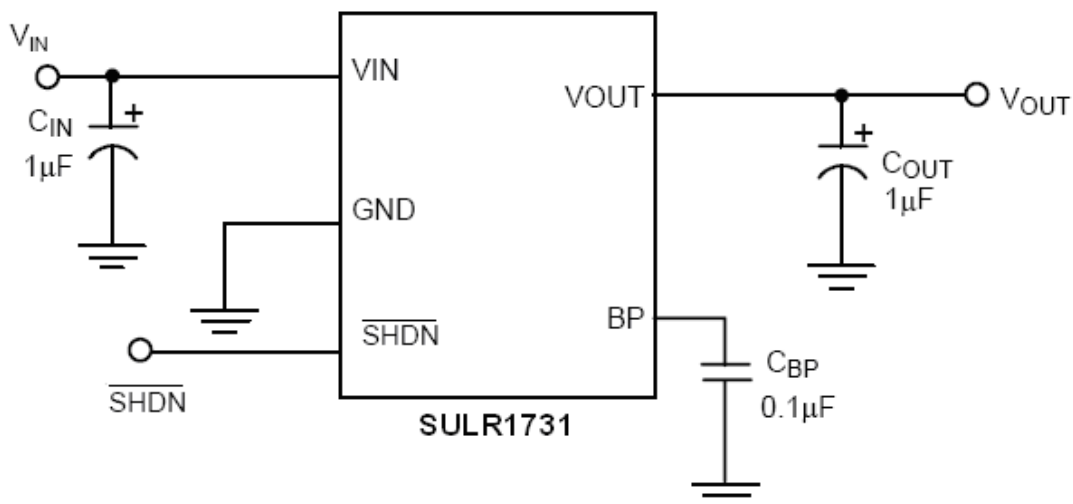

**Low Noise Low Dropout Linear Regulator**



Ordering Information:

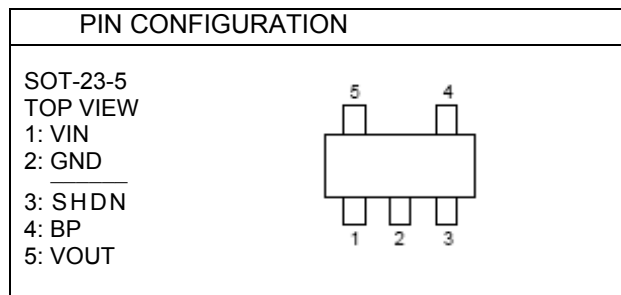
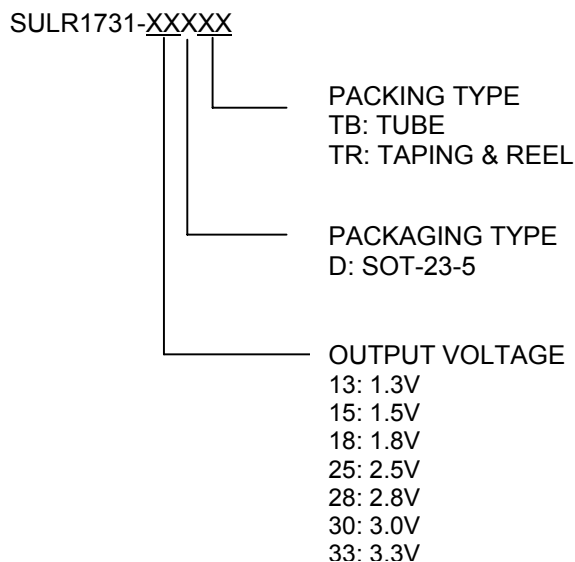

Marking Diagram:

Part No.	Marking
SULR1731-15DTR	ED15G
SULR1731-18DTR	ED18G
SULR1731-25DTR	ED25G
SULR1731-30DTR	ED30G
SULR1731-33DTR	ED33G



**Absolute Maximum Ratings:**

Supply Voltage .....	12V
Shutdown Terminal Voltage.....	8V
Noise Bypass Terminal Voltage .....	5V
Operating Temperature Range .....	-40°C to 85°C
Maximum Junction Temperature .....	125°C
Storage Temperature Range .....	-65°C ~ 150°C
Lead Temperature (Soldering) 10 sec. ....	260°C
Thermal Resistance Junction to Case SOT-23-5 .....	130°C/W
Thermal Resistance Junction to Ambient SOT-23-5.....	220°C/W

(Assume no ambient airflow, no heatsink)

Absolute Maximum Ratings are those values beyond which the life of a device may be impaired.

**Test Circuit**

Refer to TYPICAL APPLICATION CIRCUIT

**Technical Data**
**300mA, Low Dropout Linear Regulator with Shutdown**

Data Sheet N1586 Rev. -

**Electrical Characteristics( $C_{IN} = 1\mu F$ ,  $C_{OUT} = 4.7\mu F$ ,  $T_J = 25^\circ C$ , unless otherwise specified)(Note 1)**

PARAMETER	TEST CONDITIONS	SYMBOL	MIN.	TYP.	MAX.	UNIT
Quiescent Current	$I_{OUT} = 0mA$ , $V_{IN} = 3.6\sim 7V$	$I_Q$		35	50	$\mu A$
Standby Current	$V_{IN} = 3.6\sim 7V$ , output OFF	$I_{STBY}$			0.1	$\mu A$
GND Pin Current	$I_{OUT} = 0.1\sim 300mA$	$I_{GND}$		30	50	$\mu A$
Continuous Output Current	$V_{IN} = 5V$	$I_{OUT}$			300	mA
Output Current Limit	$V_{IN} = 5V$ , $V_{OUT} = 0V$	$I_{IL}$	300	450		mA
Output Voltage Tolerance	$V_{IN} = 5V$ , no load	$V_{OUT}$	-2		2	%
Temperature Coefficient		TC		50	150	ppm/ $^\circ C$
Line Regulation	$V_{IN} = V_{OUT(TYP)} + 1V$ to 7V	$\Delta V_{LIR}$		3	10	mV
Load Regulation	$V_{IN} = V_{OUT} + 1.2V$ ( $V_{out} \geq 2.0V$ ) $V_{IN} = V_{OUT} + 1.7V$ ( $V_{out} \leq 1.9V$ ) $I_{OUT} = 0.1\sim 300mA$	$\Delta V_{LOR}$		10	30	mV
Dropout Voltage	$I_L = 300mA$ $3.0V \leq V_{OUT} \leq 3.3V$ $2.5V \leq V_{OUT} \leq 2.9V$ $2.0V \leq V_{OUT} \leq 2.4V$ $1.3V \leq V_{OUT} \leq 1.9V$	$V_{DROP}$		470 570 800 1260	870 970 1200 1660	mV
Noise Bypass Terminal Voltage		$V_{REF}$		1.23		V
Output Noise	$C_{BP} = 0.1\mu F$ , $f = 1KHz$ , $V_{IN} = 5V$	$\Delta n$		0.46		$\frac{\mu V}{\sqrt{Hz}}$
Ripple Rejection	$f = 1KHz$ , Ripple = $0.5V_{P-P}$ , $C_{BP} = 0.1\mu F$	RR		55		dB
Shutdown Pin Current		$I_{SHDN}$			0.1	$\mu A$
Shutdown Pin Voltage (ON)	Output ON		1.6			V
Shutdown Pin Voltage (OFF)	Output OFF				0.6	V
Shutdown Exit Delay Time	$C_{BP} = 0.1\mu F$ , $C_{OUT} = 1\mu F$ , $I_{OUT} = 30mA$	$\Delta t$		300		$\mu S$
Thermal Shutdown Temperature		$T_{SD}$		155		$^\circ C$

**Note: 1.** To avoid output oscillation, aluminum electrolytic output capacitor is recommended and ceramic capacitor is not suggested.

**2.** Specifications are production tested at  $T_A = 25^\circ C$ . Specifications over the  $-40^\circ C$  to  $85^\circ C$  operating temperature range are assured by design, characterization and correlation with Statistical Quality Controls (SQC).

Typical Performance Characteristics

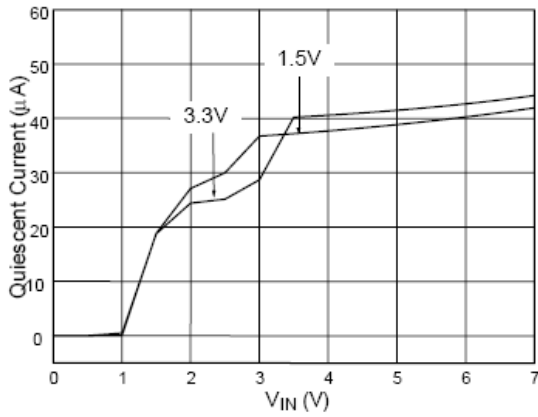

Fig. 1 Quiescent Current vs.  $V_{IN}$

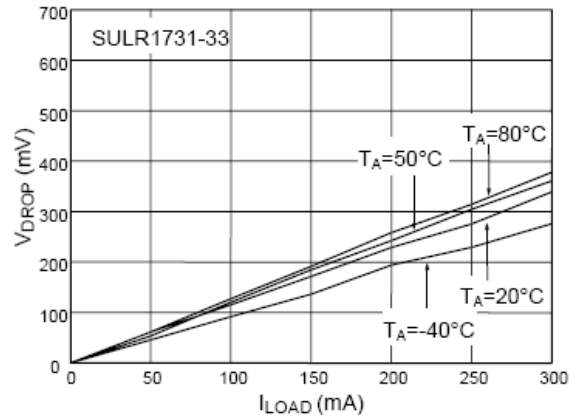

Fig. 2  $V_{DROP}$  vs.  $I_{LOAD}$

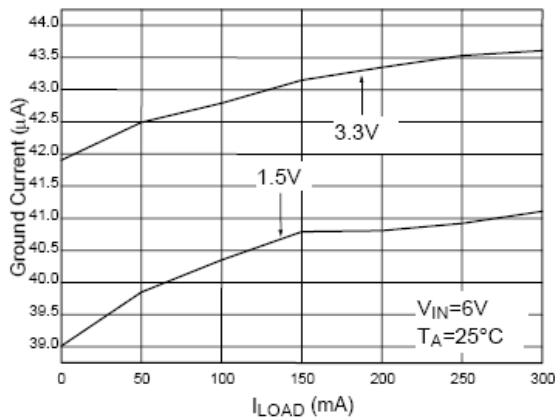

Fig. 3 Ground Current vs.  $I_{LOAD}$

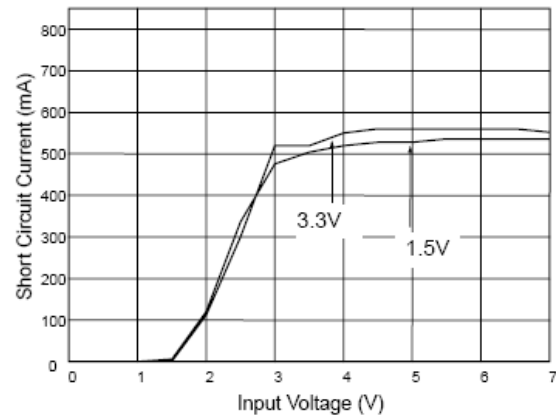

Fig. 4 Input Voltage vs. Short Circuit Current

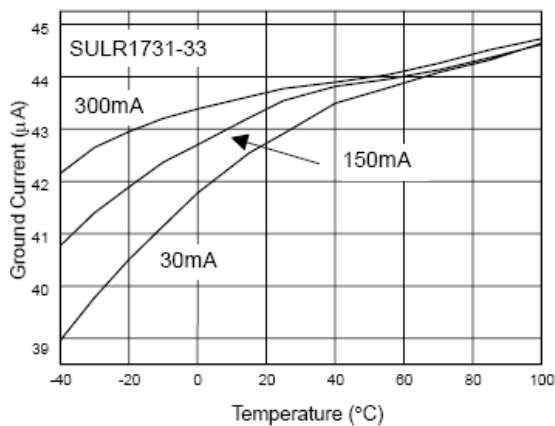

Fig. 5 Ground Current vs. Temperature

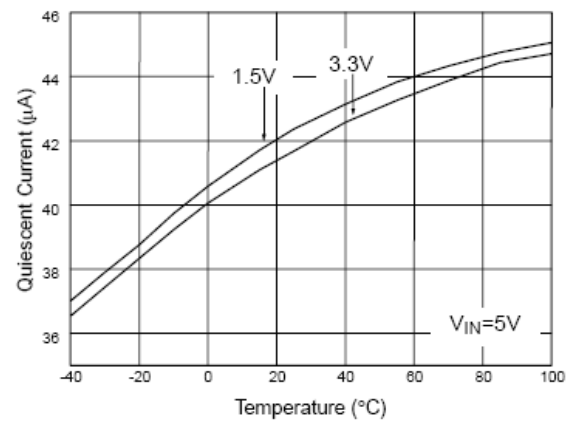

Fig. 6 Quiescent Current vs. Temperature

Typical Performance Characteristics (Continued)

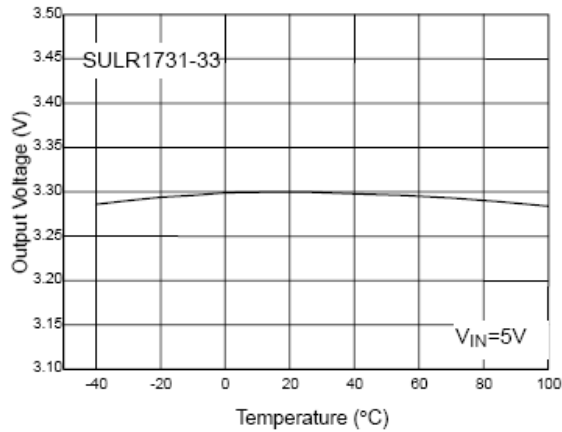

Fig. 7 Output Voltage vs. Temperature

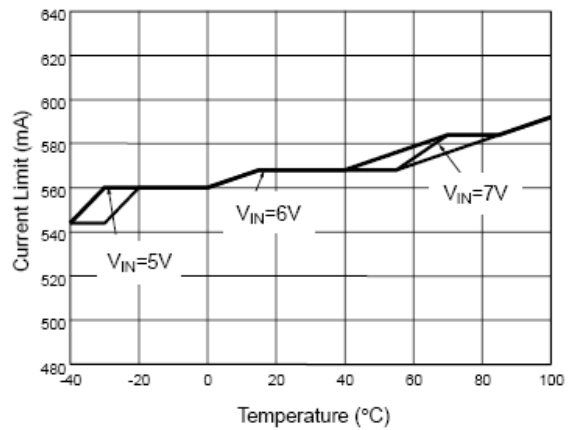

Fig. 8 Current Limit vs. Temperature

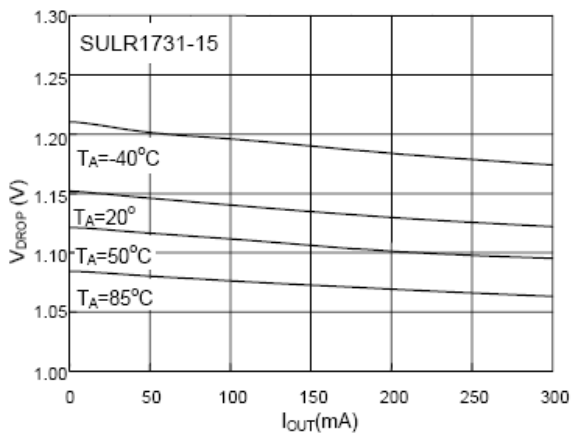

Fig. 9 V<sub>DROP</sub> VS. I<sub>LOAD</sub>

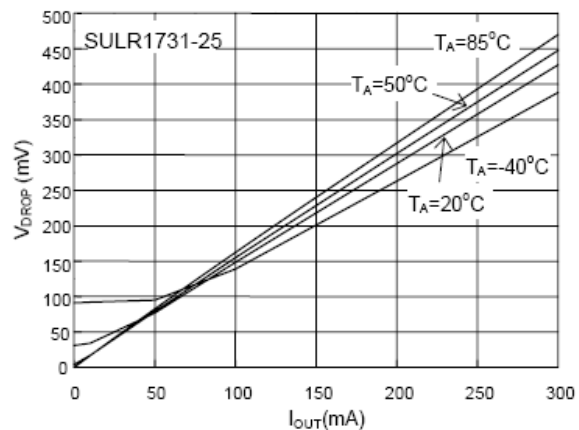

Fig. 10 V<sub>DROP</sub> VS. I<sub>LOAD</sub>

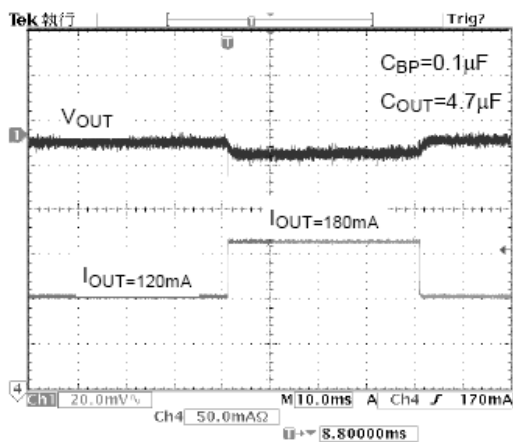

Fig. 11 Load Transient Response

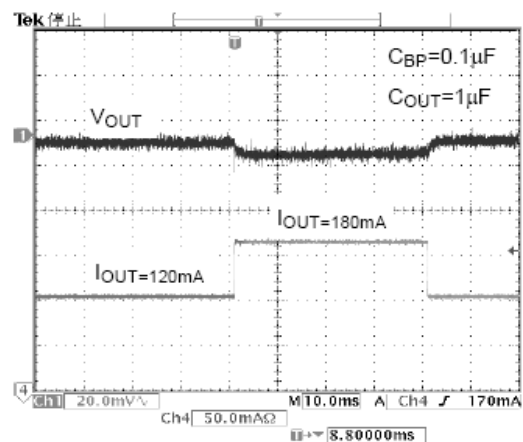

Fig. 12 Load Transient Response

Typical Performance Characteristics (Continued)

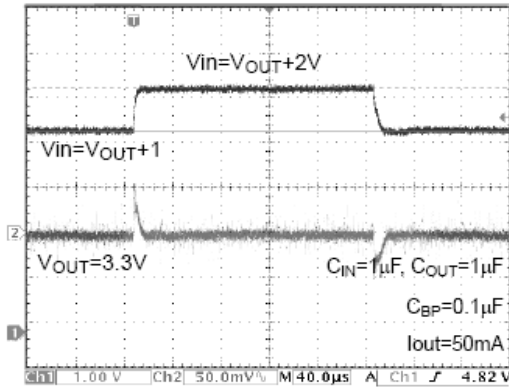

Fig. 13 Line Transient Response

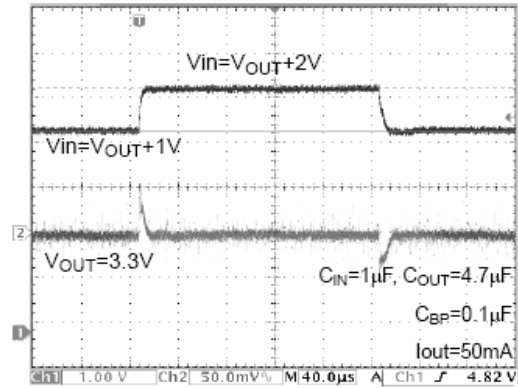

Fig. 14 Line Transient Response

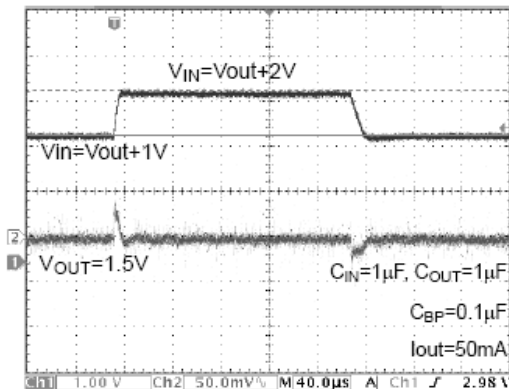

Fig. 15 Line Transient Response

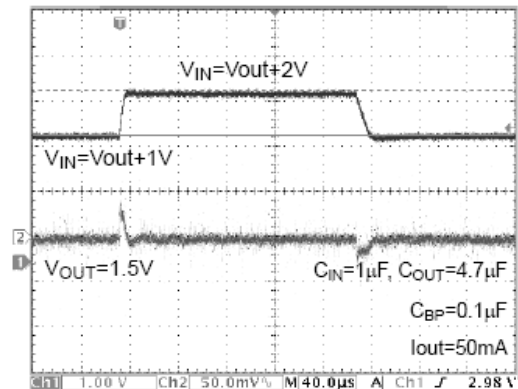

Fig. 16 Line Transient Response

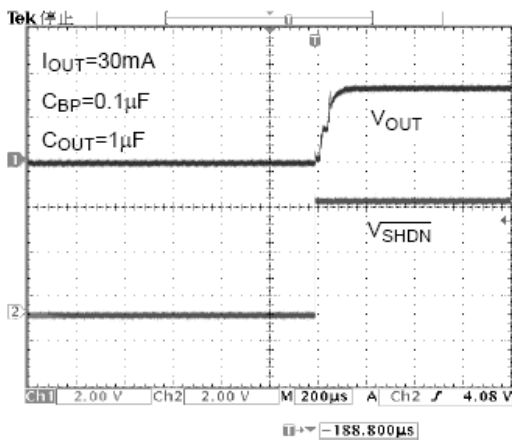

Fig. 17 Shutdown Exit Time

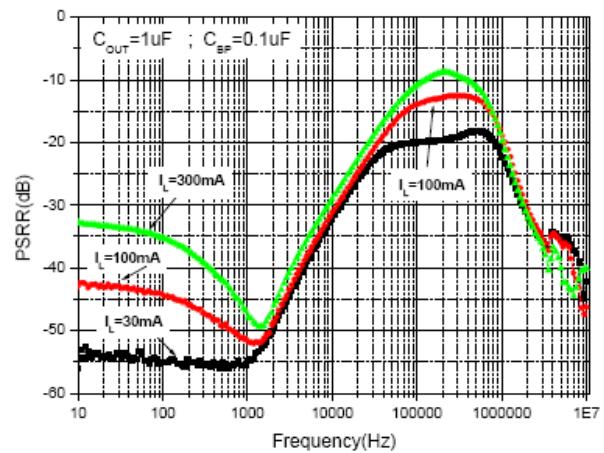
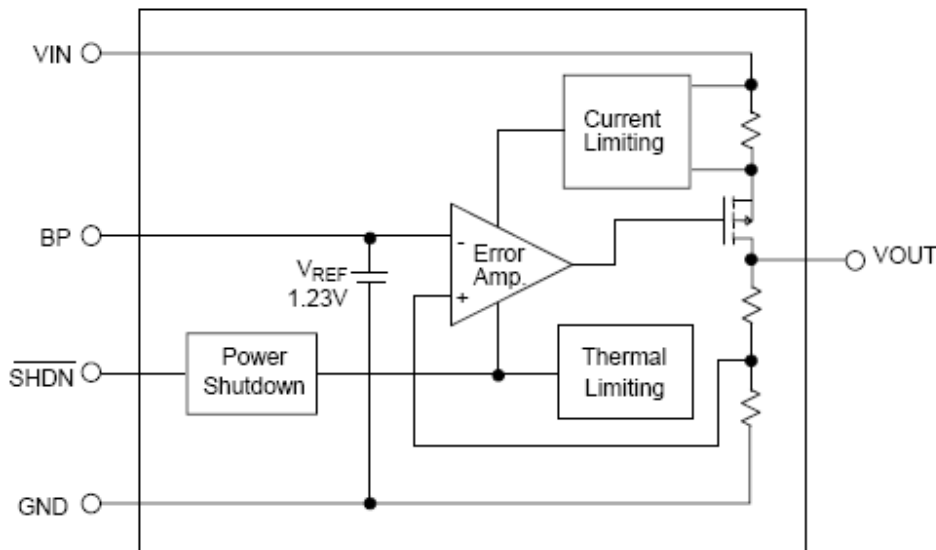

Fig. 18 Ripple Rejection

**Block Diagram**



**Pin Descriptions**

- PIN 1 : VIN - Power supply input pin. Bypass with a 1µF capacitor to GND
- PIN 2 : GND - Ground pin.
- PIN 3 : SHDN - Active-Low shutdown input pin.
- PIN 4 : BP - Noise bypass pin. An external bypass capacitor connecting to BP pin to reduce noises at the output.
- PIN 5 : VOUT - Output pin. Sources up to 300mA.





## Application Information

### INPUT-OUTPUT CAPACITORS

Linear regulators require input and output capacitors to maintain stability. Input capacitor at 1 $\mu$ F with 1uF aluminum electrolytic output capacitor is suggested.

### NOISE BYPASS CAPACITOR

0.1 $\mu$ F bypass capacitor at BP pin reduces output voltage noise. And the BP pin has to connect a capacitor to GND.

### POWER DISSIPATION

The SULR1731 obtains thermal-limiting circuitry, which is designed to protect the device against overload condition. For continuous load condition, maximum rating of junction temperature must not be exceeded. It is important to pay more attention in thermal resistance. It includes junction to case, junction to ambient. The maximum power dissipation of SULR1730 depends on the thermal resistance of its case and circuit board, the temperature difference between the die junction and ambient air, and the rate of airflow. The rate of temperature rise is greatly affected by the mounting pad configuration on the PCB, the board material, and the ambient temperature. When the IC mounting with good thermal conductivity is used, the junction temperature will be low even when large power dissipation applies.

The power dissipation across the device is  $P = I_{OUT} (V_{IN} - V_{OUT})$ .

The maximum power dissipation is:

$$P_{MAX} = \frac{(T_{J-MAX} - T_A)}{R_{\theta JA}}$$

Where  $T_{J-max}$  is the maximum allowable junction temperature (125°C), and  $T_A$  is the ambient temperature suitable in application.

As a general rule, the lower temperature is, the better reliability of the device is. So the PCB mounting pad should provide maximum thermal conductivity to maintain low device temperature. GND pin performs a dual function of providing an electrical connection to ground and channeling heat away. Therefore, connecting the GND pin to ground with a large pad or ground plane would increase the power dissipation and reduce the device temperature.

Physical Dimensions

SOT-23-5 (unit: mm)

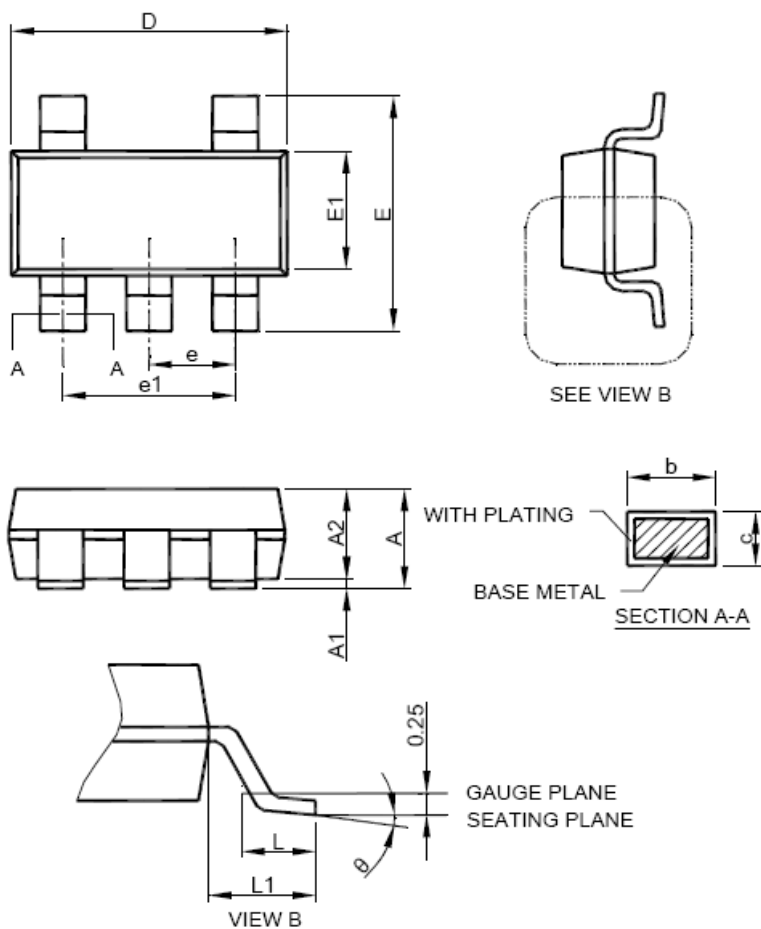

SYMBOL	SOT-23-5	
	MILLIMETERS	
	MIN.	MAX.
A	0.95	1.45
A1	0.05	0.15
A2	0.90	1.30
b	0.30	0.50
c	0.08	0.22
D	2.80	3.00
E	2.60	3.00
E1	1.50	1.70
e	0.95 BSC	
e1	1.90 BSC	
L	0.30	0.60
L1	0.60 REF	
q	0°	8°

Note: 1. Refer to JEDEC MO-178AA.

2. Dimension "D" does not include mold flash, protrusions or gate burrs. Mold flash, protrusion or gate burrs shall not exceed 10 mil per side.
3. Dimension "E1" does not include inter-lead flash or protrusions.
4. Controlling dimension is millimeter, converted inch dimensions are not necessarily exact.



**DISCLAIMER:**

- 1- The information given herein, including the specifications and dimensions, is subject to change without prior notice to improve product characteristics. Before ordering, purchasers are advised to contact the SMC - Sangdest Microelectronics (Nanjing) Co., Ltd sales department for the latest version of the datasheet(s).
- 2- In cases where extremely high reliability is required (such as use in nuclear power control, aerospace and aviation, traffic equipment, medical equipment, and safety equipment), safety should be ensured by using semiconductor devices that feature assured safety or by means of users' fail-safe precautions or other arrangement.
- 3- In no event shall SMC - Sangdest Microelectronics (Nanjing) Co., Ltd be liable for any damages that may result from an accident or any other cause during operation of the user's units according to the datasheet(s). SMC - Sangdest Microelectronics (Nanjing) Co., Ltd assumes no responsibility for any intellectual property claims or any other problems that may result from applications of information, products or circuits described in the datasheets.
- 4- In no event shall SMC - Sangdest Microelectronics (Nanjing) Co., Ltd be liable for any failure in a semiconductor device or any secondary damage resulting from use at a value exceeding the absolute maximum rating.
- 5- No license is granted by the datasheet(s) under any patents or other rights of any third party or SMC - Sangdest Microelectronics (Nanjing) Co., Ltd.
- 6- The datasheet(s) may not be reproduced or duplicated, in any form, in whole or part, without the expressed written permission of SMC - Sangdest Microelectronics (Nanjing) Co., Ltd.
- 7- The products (technologies) described in the datasheet(s) are not to be provided to any party whose purpose in their application will hinder maintenance of international peace and safety nor are they to be applied to that purpose by their direct purchasers or any third party. When exporting these products (technologies), the necessary procedures are to be taken in accordance with related laws and regulations..